



Delivery conditions

Laverana GmbH & Co KG
Am Weingarten 4
30974 Wennigsen
E-Mail: info@lavera.de
Homepage: www.lavera.de

1. Introduction

The following delivery conditions are the basis for the cooperation with Laverana GmbH & Co. KG (hereinafter referred to as Laverana). Laverana exclusively reserves the right to change the delivery conditions. Unless otherwise stipulated in these shipping instructions, the cooperation shall be governed by the GS1 manuals and standards, which are available for download on the website of GS1-Germany.

Generally, all deliveries by Seller shall be made in accordance with INCOTERMS 2022 DDP, unless the purchase order or written sales contract includes a different INCOTERM.

Laverana handles all damages to shipments delivered free to the door directly with the seller.

The Seller undertakes to inform all service providers commissioned by it, for example for logistics services and IT, of the content of the delivery instructions.

The dangerous goods regulations must be complied with.

In the event of non-compliance with these delivery instructions, Laverana reserves the right, at its own discretion, to refuse acceptance of the deliveries concerned or to charge any consequential costs, e.g. for repackaging work, production stoppages (see item 12). Previously issued delivery conditions hereby lose their validity.

2. Delivery dates and notification

The delivery dates stated in orders and contracts are binding. Changes shall only be deemed agreed if the new date is confirmed in writing by Laverana.

Laverana accepts deliveries on working days (Monday through Friday) between 7:00 am and 2:00 pm. The transport service provider must report to the gate 30 minutes before the confirmed time slot. Deliveries will not be accepted outside of these times.

For the delivery of goods with pallets, a delivery slot must be booked by 2.00 pm at least two working days before delivery. The booking is made by calling **+49 (0) 511 67541 310** between 07.00 am and 2.00 pm or by email **warenannahme@lavera.de**.

The booking request must contain:

- Our order number
- Number of pallets and trucks
- Sending company
- If used: forwarding agent



Delays or shifts must be communicated immediately and at least four hours in advance to the goods receiving department by telephone at +49 (0) 511 67541 310 between 07.00 am and 2.00 pm or by email warenannahme@lavera.de. Changes shall only be deemed to have been agreed if the new date has been confirmed in writing by Laverana.

Laverana is working on an automatic system for booking delivery slots (ramp management), which will replace booking via e-mail or telephone in the future.

If deliveries are made on a date other than the agreed delivery date, Laverana shall be entitled to refuse acceptance or to coordinate the delivery as it fits into the company's operational processes. All resulting consequences shall be at the expense of the seller.

3. Delivery

The delivery quantities stated in the orders and contracts are binding; under- and over-deliveries are generally not permitted. Changes shall only be deemed agreed if the new quantity has been confirmed in writing by Laverana.

Palletized goods must always be delivered by transport vehicles with a ramp height of at least 1.20 meter. It must be possible to place the ramp on the loading area of the truck. Unloading must be carried out exclusively from the rear of the truck. No unloading of pallets is carried out with vehicles that are not capable of ramping.

Trucks that require a ramp height lower than 1.20 meter must be notified according to point 2 of this document.

The driver of the delivering transport company must move the pallets from his vehicle to the storage and counting area in the goods receiving area. This is located directly behind the unloading ramp. Electric industrial trucks are available to the driver for this purpose.

In principle, all pallets must stand lengthwise on the vehicle. Transverse loads are not accepted.

Tankers can only be unloaded at our site in Wennigsen if they have the appropriate connections. The responsibility for this lies with the seller. The seller is also liable for consequential damages, such as production losses, which occur because unloading is not possible due to missing or unsuitable connections.

To enter the Laverana premises, the truck driver is obliged to wear closed safety shoes and a high-visibility vest. The vehicle must be secured against rolling away with chocks before unloading.

For deliveries on Euro pallets, Laverana will exclusively use the pallet exchange procedure as of 01.01.2023. Previously agreed separate arrangements lose their validity from this date. No separate pallet accounts will be maintained. Sellers are requested to inform their forwarders and their subcontractors about this new procedure by 01.01.2023. In case of non-exchange of the B-pallets and leaving the premises, the supplier forfeits his debt towards Laverana.

After receiving the goods, the transport service provider receives pallets from the Laverana pool back step by step. The exchange takes place exclusively in **quality B** according to the **GS1** quality classification, including MFH suitable (suitable for machines, conveyor technology (roller and chain conveyors) and high-bay storage).

In case of delivery of non-adequate pallets, a corresponding write-off will be made on the delivery bill and the wooden pallets will not be exchanged back.



4. Palletizing

General cargo is to be palletized on Euro pallets of at least quality B according to the GS1 standard (see also chapter 3). The details can be found in the following link:

- [GS1 poster_quality_classification_for_the_plate_exchange_pool.pdf](#).

Link:

https://www.gs1-germany.de/fileadmin/gs1/basis_informationen/poster_qualitaetsklassifizierung_fuer_den_plattentauschpool.pdf

If contractually agreed, industrial pallets with dimensions of 1.20 meter x 1.00 meter are accepted in exceptional cases. The fork clearance (with 100 millimeter -0/+3 millimeter according to EN 13698) of the pallet must be strictly observed. The film securing must not cover the fork clearance of the pallet (wrapping of the goods up to the upper edge of the fork clearance). Deviating pallet dimensions or overbuilt pallets will be refused.

Only one material (one material number), one package size and shape, and one batch may be packed on a pallet. If the material has a best before date (BBD), only one BBD may be on a pallet. Mixed pallets, i.e. pallets with more than one material or more than one batch and / or more than one best before date, will only be accepted after prior consultation and written confirmation from Laverana.

The pallet height must not exceed 1.99 meter (incl. pallet). The possible module dimensions in height are in each case 1.05 meter, 1.60 meter and less than 2.00 meter overall; measured from the pallet base to including the highest point on the top of the pallet, including the film welding seam or other product protection. If necessary, defined pallet heights shall be contractually agreed between the contracting parties.

In doing so, we expect the specified pallet heights to be utilized to the best possible extent without exceeding them. The pallet height must not change during the storage period so that the underlying module dimension is exceeded. Otherwise, there is a risk that the pallets can no longer be retrieved or that the high-bay warehouse will be damaged. The weight of a pallet, including the load carrier (basically a wooden euro pallet), must not exceed 1.000 kg.

Each pallet must be secured for transport and MFH (machines, conveyor technology, high-bay warehouse - see GS1 for details). A stable bond between the goods and the pallet must be ensured. The fork clearances must be kept completely free, i.e. stretch and shrink films may only enclose the two cover boards. Neither film nor tapes or similar may hang down loosely. The securing must not damage the delivered goods or their outer packaging. Loose slips or slips additionally attached to the pallet are to be strictly omitted in view of the conveyor technology and may lead to refusal of acceptance.



Example of pallets that do not meet the criteria and lead to refusal of acceptance:

Residues foil



Fork clearance



Compliance dimensions no protrusion laterally, frontally and in height



Example of a pallet that meets the criteria required by Laverana:

All right

suitable for machines,
conveyor technology
and high-bay storage



Fork free space with 100 mm -0/+3 mm according to EN 13698

Deviating pallet dimensions and types will only be accepted if expressly agreed in the order or contract. Pallets other than Euro pallets will neither be exchanged nor refunded.

5. NVE labeling

All pallets and all packages that are not palletized by type (one material, one package, one batch, one best before date) must be delivered with two NVE labels in accordance with the GS1 standard. The details can be found in the following links:

- *NVE_in_application.pdf* with link:
https://www.gs1-germany.de/fileadmin/gs1/fachpublikationen/NVE_in_der_Anwendung.pdf
- *quick_guide_gs1_transport_label.pdf* with link:
https://www.gs1-germany.de/fileadmin/gs1/basis_informationen/gs1-germany-quick-guide-gs1-transportetikett-praesentation.pdf



GS1 transport label for a mixed pallet
(principle illustration)

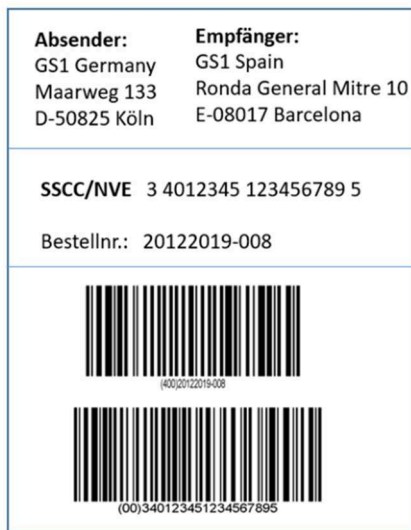

GS1 transport label with single-variety trading
units



Placement: cartons and outer packaging

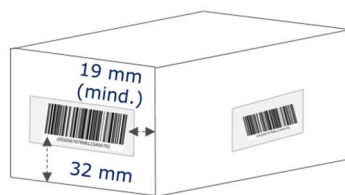

Placement: Pallets

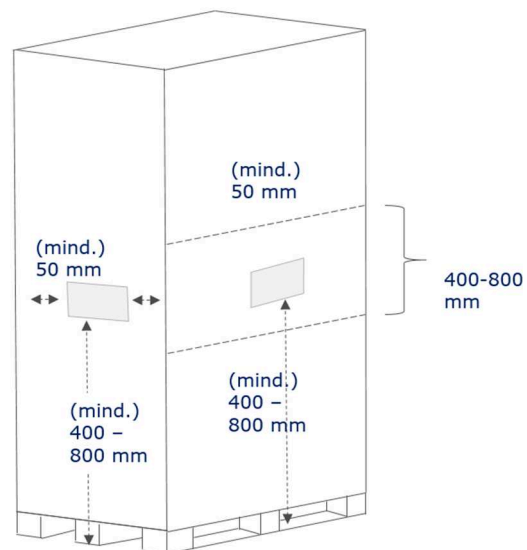

6. Packing

All materials must be packed according to the specifications in the purchase order. The package sizes specified in the order must be strictly observed. The goods must not exceed the dimensions of the pallet in any case.

The dimensions of the packages must be based on pallet dimensions, MFH suitability and optimum volume utilization. The total weight of a single package must not exceed 30 kilogram, unless Laverana specifies otherwise in writing in the order.

Before an initial delivery, Laverana must be completely familiar with the logistical data requested by the purchasing department. The logistical data is product-specific and includes information on pallet dimensions, weights, dimensions of outer cartons, etc.



7. Dangerous goods

All legal and official regulations regarding the transport and handling of hazardous goods and substances must be complied with. Deviating regulations in orders and contracts are void. It is the seller's responsibility to inform Laverana if contractual regulations contradict the regulations.

Each delivery of a hazardous substance must always be accompanied by the corresponding safety data sheet. Only hazardous substances for which Laverana has previously confirmed receipt of the corresponding safety data sheet in writing are exempt from this regulation. Any safety-related markings must be affixed to each individual container and to each outer packaging.

8. FEFO

MHD (best before date) listed goods must be delivered according to the FEFO principle (First Expire First Out). Goods without a best before date must be delivered according to the FIFO principle, i.e. the oldest batch must be delivered first. Deliveries that deviate from the above principle will not be accepted.

9. Freight and delivery documents

Each shipment must be accompanied by complete freight and delivery documents. General cargo-, part loads and full truck consignments must be accompanied by a consignment note, which must be presented by the carrier upon registration at our warehouses.

Each shipment shall be accompanied by a detailed paper delivery bill containing at least the following information:

- Name and full address of the supplier
- Name and full address of the recipient
- Shipping date
- Laverana order number
- Complete packing list with
 - Laverana article numbers
 - Laverana article designations
 - Batches
 - Container sizes and type
 - Quantity per pallet and quantity per container
 - MHD, if required
- Certificates of analysis for commodities
- RSPO relevant documents and information for raw materials
- Material Safety Data Sheets (MSDS) for hazardous materials

The delivery bill must be attached to the outside of one of the pallets or the package in a commercially available delivery note pocket so that it is clearly visible. A copy of the delivery bill shall be presented to the receiving department for verification. If a shipment consists of several packages, a copy of the delivery note shall be attached to each package. In addition, packages belonging to one shipment are to be identified accordingly. The package number and the total number of packages in the shipment must be indicated, e.g. "1/3" (one of three), "2/3" and "3/3".

It is mandatory that all freight and delivery documents contain Laverana's order and material number(s). A single delivery bill must be created for each order. Several delivery bills may then be combined into one shipment. If several delivery bills are delivered on one pallet, the packages must



be marked with the last three digits of the respective delivery bill in such a way that sorting onto the delivery bills is made quick and easy. This regulation applies analogously to parcel shipments.

Typical delivery errors that lead to refusal of acceptance are:

- Fork clearance too small due to pallet quality
- Fork clearance too small due to film stretched too deep
- Fluttering, loose films, thus not suitable for automatic storage
- Missing order number
- wrong pallet type
- Missing customer material number
- Missing MHD
- missing delivery bill
- missing certificates
- Protrusion of the goods
- Cross loading

Content questions:

- Head of Strategic Purchasing, Phone +49 511-67541 355
- Head of Logistics, Phone +49 511 67541 308

10. Electronic data interchange

Laverana aims to exchange data with its suppliers via EDI (Electronic Data Interchange) in the future. Based on the standards of GS1-Germany, EANCOM and EDIFACT, orders, order confirmations, shipping notifications, invoices, etc. are to be transmitted electronically.

Contact: Head of Logistics, Phone +49 (0) 511 67541 308

11. Receipt

Laverana shall acknowledge receipt of the shipment units, number of packages or pallets to the delivering transport service provider. Open defects entitle Laverana to refuse acceptance. All costs resulting from a refusal of acceptance shall be borne by the seller. This also explicitly applies to consequential costs incurred by Laverana.

If Laverana decides to accept deliveries with open defects in exceptional cases, this will be noted on the delivery documents. In order to be able to store and use the delivery, Laverana must transfer the goods to a condition in accordance with our delivery conditions. Laverana shall be entitled to charge seller for the resulting costs in accordance with item 12 of this document and to deduct them from the next payment.

The right to claim further costs and damages arising from defective delivery shall remain unaffected - in particular with regard to hidden defects.

12. Cost rates for deviations

In principle, Laverana reserves the right to charge a processing fee of € 150.00 for each delivery that does not comply with these delivery conditions or does not comply with the order.

In addition, the seller shall bear all costs resulting from non-compliance with these delivery conditions, which Laverana shall determine at its own expense to eliminate the deviations from these delivery conditions and charge to the supplier in accordance with the expense (underlying hourly rate = 30 €).

